

FSUE PA "NOVOSIBIRSK  
INSTRUMENT-MAKING PLANT"



# OPTICAL SIGHTS PO3-9x24, PO3-9x24-1

Instruction manual  
AL3.812.232 RE

**Because of continuous modernization of Sights, their construction may have some corrections, not indicated in the given manual.**

---

Изделие ПОЗ-9х24, ПОЗ-9х24-1.  
Руководство по эксплуатации на англ. яз.

Instruction manual describes operation, technical characteristics, performance features and main rules of correct exploitation and using of technical opportunities.

## **1 PURPOSE**

Pancratic optical Sights PO3-9x24, PO3-9x24-1 (hereinafter referred to as the Sight) with alternating magnification from 3x to 9x are intended for adjustment on hunting weapon. PO3-9x24 Sight is adjusted on the “Tiger” rifle, PO3-9x24-1 Sight is adjusted on the “Saiga” rifle.

Reticule illumination allows aiming at twilight and night.

PO3-9x24 and PO3-9x24-1 Sights are designed for operating in ambient temperature range from -40 °C to +40 °C and relative humidity up to 95% at temperature +25 °C.

## 2 SPECIFICATIONS

Magnification ,x	from 3	to 9
Angular field of view	6°	2°
Resolution range, s	20	8,5
Exit pupil diameter, mm	3,9	2,6
Eye relief, mm	71,6	70
Diopter adjustment, d	From -0,5	to -1
Overall dimensions, mm	410x136x72	
Weight, maximum kg	1,0	

## 3 NOMENCLATURE LIST

Sight	1
Key	1
Eyeshield	1 removed off the Sight
Box	1
Instruction manual	1

## 4 PREPARATION FOR USE

Mount the Sight on the weapon and make an adjustment before use.

Put an eyeshield before mounting on the weapon.

Attach the Sight to the weapon with a mounting.

Shift the mounting latch 6 (fig.1) up to the stop, align the mount slot of the Sight with the dovetail mount rail of rifle, push the Sight up to the stop and secure it by turning the handle 6 forward – for the Sight PO3-9x24; backward – for the Sight PO3-9x24-1 up to the complete fixation.

The Sight must be fastened secure. If the Sight sways or the latch 6 does not shut when the Sight is fastened, regulate the mounting latch in the following way:

- take the Sight off a weapon;
- push the slider 7 in the bottom part of the mounting until pressing of the spring 9;
- shift the nut 8 on 1-2 teeth counter-clockwise or clockwise;
- check the mounting and repeat the regulation if necessary.

The Sight is adjusted on the rifle after zeroing in with opened sight (aim and sight). Adjust it by the following:

- attach the Sight to the weapon;
- place the upper handwheel 2 on the point “3”, the side handwheel 1 (fig.2) – on the point “0”;
- align the rifle by the opened Sight with a point “3” at the 100m distant target;
- look through the objective, notice the aiming point position;

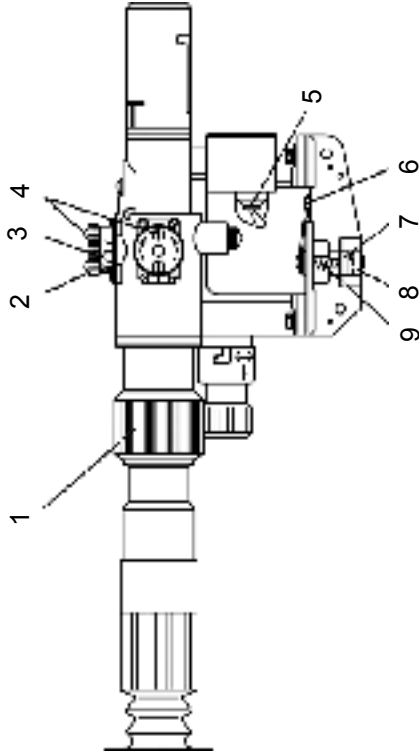

- 1 – magnification change handwheel; 2 – upper handwheel;  
 3 – aiming angles scale; 4 – screw; 5 – tumbler;  
 6 – latch; 7 – slider; 8 – nut; 9 – spring

Figure 1 – **PO3-9x24 Sight (right-side view)**

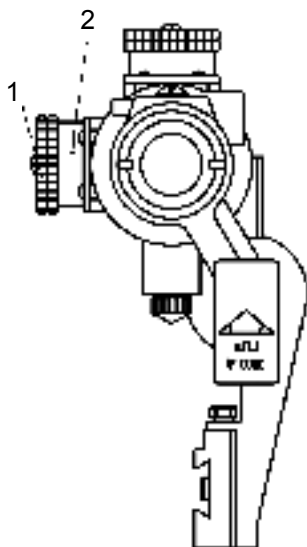

- 1 – side handwheel;
- 2 – side corrections scale

**Figure 2 – PO3-9x24  
Sight (objective-side view)**

- if the aiming sign coincides with the aiming point of the opened sight, the Sight is adjusted;
- otherwise, shift screws 4 at 1-2 turns on the upper and side handwheels according to figures 1,2, coincide the aiming sign with the aiming point of the opened Sight by turning these handwheels (scale 3, figure 1 and scale 2, figure 2);
- turn up the screws 4 (fig.1) of handwheels up to the stop and check the coincidence of aiming sign with aiming point of the opened sight one more time. Repeat the adjustment if necessary.

## **5 OPERATION**

The upper handwheel adjustment must be determined operationally, depending on the firing distance.

The Sight can be produced with one of three reticules according to figures 3, 4, 5 – Aiming reticule.

The choice of the target with PO3-9x24 and PO3-9x24-1 Sights executes with 3x magnification. Aim firing operates with larger magnification.



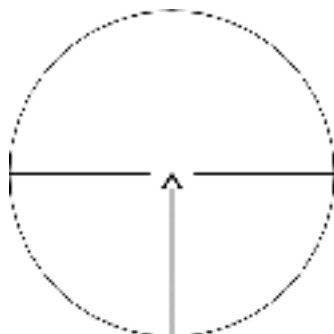

Figure 3 – **Aiming reticule**

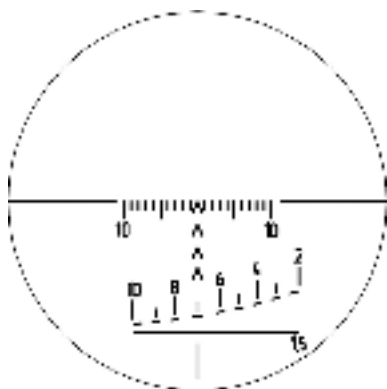

Figure 4 – **Aiming reticule**

The distance to the target can be determined by using of range scale of the reticule according to figure 4.

To determine the distance according to range scale of the reticule by the height of a target of 1,5 m, aim the scale on the target so that the target is placed between the continuous horizontal and dotted inclined lines. Scale stroke above the target indicates the distance to the target.

The scale value of the side correction on the reticule is 10 cm for 100 m.

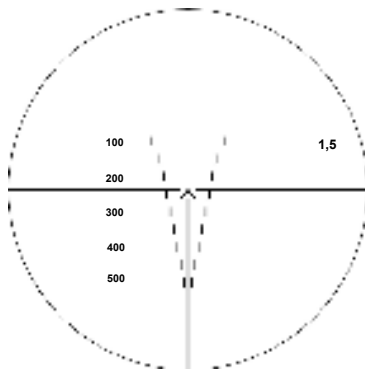

Figure 5 – **Aiming reticule**

The distance to a target may be determined by using a range scale, located on the Sight reticule and intended for the 1,5 m long target according to figure 5.

To determine the distance to a 1,5 m long target, combine the image of the target with the vertical strokes of the range scale. A number, located near the point of contact, will indicate the distance to the target for 100 m.

The Sights are equipped with the reticule illumination for aiming in the twilight or in the night, illumination switches with the "On-Off" tumbler 5 (fig.1). Any battery of A-316 type and 1,5W voltage may be used as a charge for the illumination. The emissive device AGI-18V is a light source, so the field of view has red background when the reticule illumination is switched on.

## **6 MAINTENANCE AND STORAGE**

Avoid mechanical failures.

Clean outer optical surfaces with clean soft fabric, remove oil spots and dust with a wet in alcohol cotton.

Protect optical details from scratches during storage and operation.

## **7 SAFETY**

Be ensured, that the mounting is attached to the rifle secure. Adjust the clamp of a mounting as indicated in the part 4, if the Sight sways.

## **8 WARRANTY**

The manufacturer guarantees that a Sight complies with the requirements of Technical Specifications if the user follows the rules of maintenance and storage, indicated in the manual.

The guarantee period is 24 months from the date of selling through the retail chain. If the sale date is not indicated and there is no stamp of the store in the "Acceptance certificate", the guarantee period counts from the date of the Sight manufacturing.

## 9 ACCEPTANCE CERTIFICATE

Sight PO3-9x24 (PO3-9x24-1), serial number \_\_\_\_\_, meets the specifications and state standards and is accepted for service.

Date of manufacturing \_\_\_\_\_

Representative of DTC \_\_\_\_\_

Packer \_\_\_\_\_

Stamp

Manufacturer:

FSUE PA "Novosibirsk  
Instrument-making Plant"  
Russia, 630049, Novosibirsk  
D. Kovalchuk, 179/2  
Tel., Fax +7 383-226-15-94  
e-mail: prinsib@sol.ru  
www.npzoptics.ru

“3/H”