



OPTICAL SIGHT  
**P04x24**

SERVICE MANUAL



# CONTENTS

1. DESCRIPTION AND OPERATION .....	3
1.1 Purpose .....	3
1.2 Specifications .....	4
1.3 Complete Set .....	5
2. INTENDED USE .....	6
2.1 Preparation of the Sight for Use .....	6
2.2 Proper use .....	10
3. STORAGE AND MAINTENANCE RULES .....	12
4. SAFETY REQUIREMENTS .....	13
5. ACCEPTANCE CERTIFICATE .....	14



**OPTICAL SIGHTS** P04x24,  
P04x24-1

# 1 DESCRIPTION AND OPERATION

## 1.1 Purpose

PO4x24 sights (hereinafter referred to as «the sights») are designed for mounting on hunting weapons. PO4x24 and PO4x24-01 are mounted on the weapon of «Tigr» type PO4x24-1 and PO4x24-1-01 are mounted on the weapon of «Saiga» type.

The sights are provided with two handwheels with scales to adjust the sights in windage and elevation planes when zeroing and shooting.

The sights are designed for outdoors operation within a temperature range from -40°C to +40°C and relative humidity up to 95% at a temperature of +25°C. 2

## 1.2 Specifications

Table 1

Parameter	Value
Magnification, x	4
Field of view , grad	6
Resolution limit, sec	12
Exit pupil, mm	6
Eye relief, mm	68
Diopter adjustment, d	from -0.5 to -1
Overall dimensions, mm <ul style="list-style-type: none"><li>• PO4x24</li><li>• PO4x24-1</li></ul>	337x75x140 337x75x145
Weight, kg, max <ul style="list-style-type: none"><li>• PO4x24</li><li>• PO4x24-1</li></ul>	0,8 0,85

## 1.3 Complete Set

Table 2

Description	Quantity	Notes
Sight	1	
Spanner	1	
Eyeshield	1	separated from the sight
Cover	1	
Napkin	1	
Box	1	
Service manual	1	

## 2 INTENDED USE

### 2.1 Preparation of the Sight for Use

Before using the sight perform a zeroing of a weapon with iron sight(front sight and back sight) by a shield located at the distance of 100 m.

Pull out the sight from the pack unit and wipe mounting seats of the sight and weapon.

Put the eyeshield on the eyepiece of the sight.

To mount the sight on a weapon:

- turn the bracket latch 5 (Figure 1) aside up to the stop;
- place the bracket rail of dovetail type on a weapon seat and shift the sight ahead up to the stop;
- secure the sight by turning the bracket latch 5 up to the complete fixation.

The sight must be securely fastened to a weapon seat.

If the sight sways or the bracket latch 5 does not shut when the sight is fastened, it is necessary to adjust the bracket clamp of the sight in the following way:

- take off the sight from a weapon;



## Figure 1 - P04x24

Right side view (protective caps of the adjustment mechanism handwheels not shown)

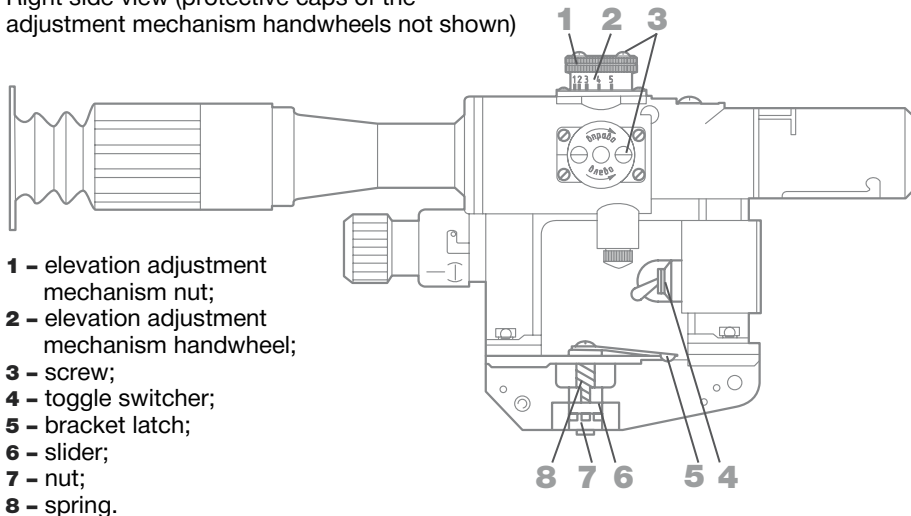

INTENDED USE

- push the slider 6 until compression of the spring 8;
- turn the nut 7 by 1–2 teeth counter-clockwise or clockwise;
- check the fastening of the sight to a weapon and repeat the adjustment if necessary.

To adjust the sight:

- remove protective caps from the adjustment mechanism handwheels;
- set the elevation adjustment mechanism handwheel 2 (Figure 1) of the sight at the point «1», the windage adjustment mechanism handwheel 2 (Figure 2) – at the point «0»;
- check the coincidence of the aiming mark in the sight field of view and the aiming point of the iron sight;
- if the aiming mark coincides with the aiming point of the iron sight on a shield, the sight is considered to be adjusted;
- otherwise, unscrew the screws 3 (Figure 1) by 1-2 turns on elevation and windage adjustment mechanism handwheels in accordance with Figures 1, 2, and align the aiming mark with the aiming point of the iron sight by turning nuts 1 (handwheel 2 (Figure 1) and (handwheel 2(Figure 2), must be kept in initial position);

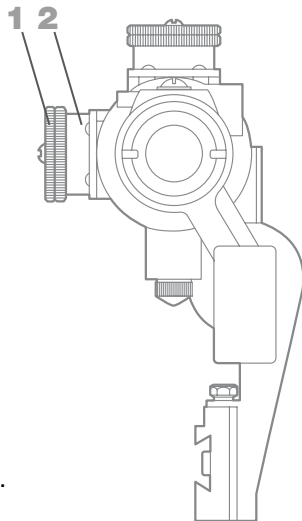

**Figure 2 - P04x24**

Objective side view  
(protective caps of the adjustment  
mechanism handwheels not shown)

- 1** - windage adjustment mechanism nut;
- 2** - windage adjustment mechanism handwheel.

- carefully screw down the screws 3 up to the stop and check again the coincidence of aiming mark with aiming point of the iron sight. Repeat adjustment if necessary.
- upon completion of adjustment put the protective caps on the adjustment mechanism handwheels.

## **2.2 Proper use**

Elevation adjustment mechanism handwheel setting must be determined experimentally according to the type of a weapon and firing distance. The turn of the elevation adjustment mechanism handwheel by one click shifts the point of impact upwards (downwards) by 2.5 cm for each 100 m.

The turn of the windage adjustment mechanism by one click shifts the point of impact to the right (left) by 2.5 cm for each 100 m. The sight can be completed with one of the two reticles according to Figures 3, 4.

Distance to a target can be determined by using the range finding scale of the sight reticle according to Figure 4.

To determine the distance with a range finding scale of the reticle using the height of a target of 1.5 m, aim the scale at the target so that the target is placed between

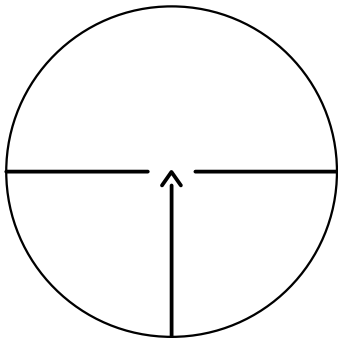

**Figure 3 - Field of view**  
PO4x24, PO4x24-1

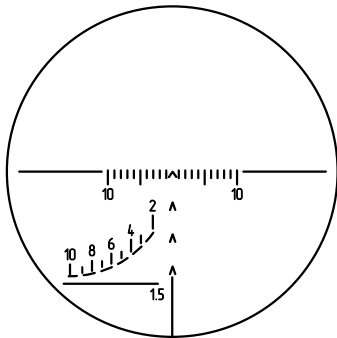

**Figure 4 - Field of view**  
PO4x24-01, PO4x24-1-01

the solid horizontal and dotted slant lines. Scale stroke above the target indicates the distance to the target.

The sights are equipped with the reticle illumination for aiming under twilight conditions, to switch it on with the toggle switcher 4 (Figure 1). A battery of AA type with the voltage of 1.5 V is used as a power source for illumination. The strokes of the reticle are red when the reticle illumination is on.

### **3 STORAGE AND MAINTENANCE RULES**

Protect the sights from mechanical damage. Protective caps of the adjustment mechanism handwheels should be removed only for using the handwheels.

Wipe the outer optical surfaces with a clean soft cloth, remove oil spots and thin coatings with the cotton wool wetted with alcohol.

Protect optical parts of the sight from the scratches during storage and operation.

To protect the sight from mechanical and climatic exposure use the cover from the complete set.

## **4 SAFETY REQUIREMENTS**

During the sight operation, ensure firm fastening of it on a weapon.

If the sight sways, it is necessary to adjust the clamp of a bracket according to 2.1.

## 5 ACCEPTANCE CERTIFICATE

PO4x24 \_\_\_\_\_ sight, serial number \_\_\_\_\_, is manufactured and accepted in accordance with the requirements of mandatory state requirements, current technical documentation and is found fit for operation.

Date of issue \_\_\_\_\_

Signatures \_\_\_\_\_

JSC «Novosibirsk Instrument – making plant»  
179/2, D.Kovalchuk str  
630049, Novosibirsk  
Russia

For more information visit: [www.npzoptics.com](http://www.npzoptics.com) or e-mail: [sales@npzoptics.ru](mailto:sales@npzoptics.ru)











[www.npzoptics.com](http://www.npzoptics.com)