



**PO2.8×18 S1,
PO2.8×18 S2,
PO2.8×18 S3
SIGHTS
SERVICE MANUAL**

**PO2.8×18 S1,
PO2.8×18 S2,
PO2.8×18 S3
SIGHTS**

Service Manual

PO2.8x18 21
PO2.8x18 22
PO2.8x18 23
RIGHT
Service Manual

CONTENTS

	Page
1 General Instructions	4
2 Specifications	6
3 Delivery set	6
4 Design and Operation	7
5 Preparation and Operation Procedure	8
6 Storage and Maintenance Rules	10
7 Safety Requirements	10
8 Acceptance Certificate	11
Appendix List of Figures	12

1 GENERAL INSTRUCTIONS

PO2.8×18 S1, PO2.8×18 S2, PO2.8×18 S3 optical sights, hereinafter referred to as "the sight", are designed to perform aimed firing from hunting rifled weapon "Saiga" having side mounting seat of dovetail type during the day, in the twilight and at night under conditions of target visibility.

Modifications of the sight in accordance with the type of the weapon are described in Table 1.

Table 1

Designation	Name	Type of weapon
ASCHE3.812.141-01	PO2.8×18 S1	"Saiga" with mounting rail located at the distance of 290 mm from back plate
-02	PO2.8×18 S2	"Saiga" with mounting rail located at the distance of 270 mm from back plate
-03	PO2.8×18 S3	"Saiga" with mounting rail located at the distance of 365 mm from back plate

The sight operates within the ambient temperature range from minus 40 °C to plus 50 °C and relative humidity of up to 98 % at temperature of 25 °C.

To provide non-failure operation of the sight it is necessary to observe the following rules:

- learn the Service Manual before use of the sight;
- protect the sight from shocks and damages;
- do not touch the optical surfaces with your hands;
- close the objective of the sight with the cover 1 (Figure 1, 3, 4) during breaks in operation.

IT IS PROHIBITED:

- TO USE THE INSECURE FASTENED SIGHT.

2 SPECIFICATIONS

Magnification, x	2.8±0.14
Field of view, min	13 °
Exit pupil, mm, min	6
Eye relief, mm, min	32
Limiting resolution, max	19"
Aperture ratio, min	0.7
Adjustment range of the sight, mils, min:	
vertical	±0-10
horizontal	±0-10
Overall dimensions, mm, max:	
PO2.8×18 S1	200×90×173
PO2.8×18 S2	190×90×173
PO2.8×18 S3	274×90×173
Weight (without bracket), kg	0.57

3 DELIVERY SET

Sight PO2,8×18	1
Cover	1
Spanner	1
Napkin	1
Bag	1
Service Manual	1

4 DESIGN AND OPERATION

4.1 The sight is a day telescopic device. The sight consists of the objective, prism erecting system, reticle, elevation and windage adjustment mechanisms, light source and eyepiece, placed in the body 2 (Figure 1, 3, 4).

4.2 The bracket 5 with the side mounting seat of dovetail type is fastened on the lower part of the body for mounting the sight on the hunting weapon of "Saiga" type.

4.3 Rubber eyeshield 3 is fastened on the eyepiece with the help of the clamp 4 to provide comfortable and safe usage of the sight during firing.

4.4 There are the aiming mark 1 (Figure 5), one vertical and two horizontal lines in the field of view of the reticle.

4.5 During exploitation of the sight the cover 1 (Figure 1, 3, 4) can be flipped up to 105°, turned around the sight's optical axis and fixed in different positions by the spring plunger. It is intended for protecting the sight from flares.

4.6 Elevation and windage adjustment mechanisms covered with threaded caps 1, 2 (Figure 2) are intended for alignment of the sight with a weapon and have a discrete shift with fixation.

5 PREPARATION AND OPERATION PROCEDURE

5.1 Do the following to mount the sight on the weapon:

- take the sight out from the bag and wipe the external optical surfaces with the napkin from the delivery set;

- mount the sight on the side mounting rail of dovetail type of the weapon (Figure 1, 3, 4). When adjusting, it is necessary to turn the handle 8 back, place the sight onto the mounting seat of the weapon up to the stop and then fix the handle 8 till its latch hooked on the bracket 5;

- put the soft cover from the delivery set on the sight for protecting it from the external impacts.

5.2 In case of insecure fastening the sight on a weapon do the following:

- turn back the handle 8 and remove the sight from the weapon;

- disengage the latch 6 lug with the handle 8;

- turn the latch 6 by 90° and take it off from the bracket;

- take away the handle 8 from the teeth of the screw 7;

- turn the screw 7 by a little angle with the help of the spanner;

- engage the handle 8 with the teeth of the screw 7 and place the latch 6 back;

- mount the sight on a weapon;

- check the fixation of the sight on the weapon and if necessary repeat step 5.2.

The sight must be fastened secure on the seat of a weapon.

5.3 To carry out an adjustment of the sight on a weapon you need to do the following:

- fix the sight on the mounting seat of a weapon in accordance with step 6.1;

- make four single shots, thoroughly and evenly aiming by the peak of an aiming mark through the sight at the center of a target (Figure 6);

- determine the position of the mean point of impact (hereinafter – MPI);

- if accuracy of hits is normal MPI has to match with an aiming point or deviate from it in any direction for not more than 5 cm;

- when MPI is more than 5 cm upper or lower than the aiming point, you have to turn the elevation adjustment screw with the help of the spanner in accordance with the ring's marking;

- when MPI deviates more than 5 cm to the right or to the left than the aiming point, you have to turn the windage adjustment screw with the help of the spanner in accordance with the ring's marking.

The turn of the elevation and windage adjustment screws by 1 click gives shift of the MPI up (down), to the right (to the left) for 3 cm at the distance of 100 m.

5.4 When shooting, combine the peak of an aiming mark with the aiming point.

6 STORAGE AND MAINTENANCE RULES

It is banned to disassemble the device during the operational process!

Protect the device from mechanical damages to exclude the destruction of optical details and the light element, which is included into the light source.

External optical surfaces are to be wiped with a clean soft napkin; fat stains and coating are to be removed with a cotton wool or a napkin, saturated with an alcohol.

Protect optical details from scratches during operation and storage.

Store the device in a bag.

Optimal storage conditions are at temperature from 5 to 40 °C and at relative humidity not more than 85%.

7 SAFETY REQUIREMENTS

When using the sight ensure its secure fastening on a weapon.

8 ACCEPTANCE CERTIFICATE

PO2.8×18 S7 serial № _____, is manufactured in accordance with the requirements of mandatory state requirements, effective technical documentation and is found fit for operation.

Date of issue _____

Signatures _____

JSC «Shvabe – Defense and Protection»
179/2, D.Kovalchuk str.,
Novosibirsk, 630049
Russia
e-mail: sales@npzoptics.ru.
www.npzoptics.com

APPENDIX
List of figures

- Figure 1 – PO2.8×18 S1 Sight. Side view
- Figure 2 – PO2.8×18 S1 Sight. Front view
- Figure 3 – PO2.8×18 S2 Sight. Side view
- Figure 4 – PO2.8×18 S3 Sight. Side view
- Figure 5 – Field of view
- Figure 6 – Sight adjustment on the weapon with a target

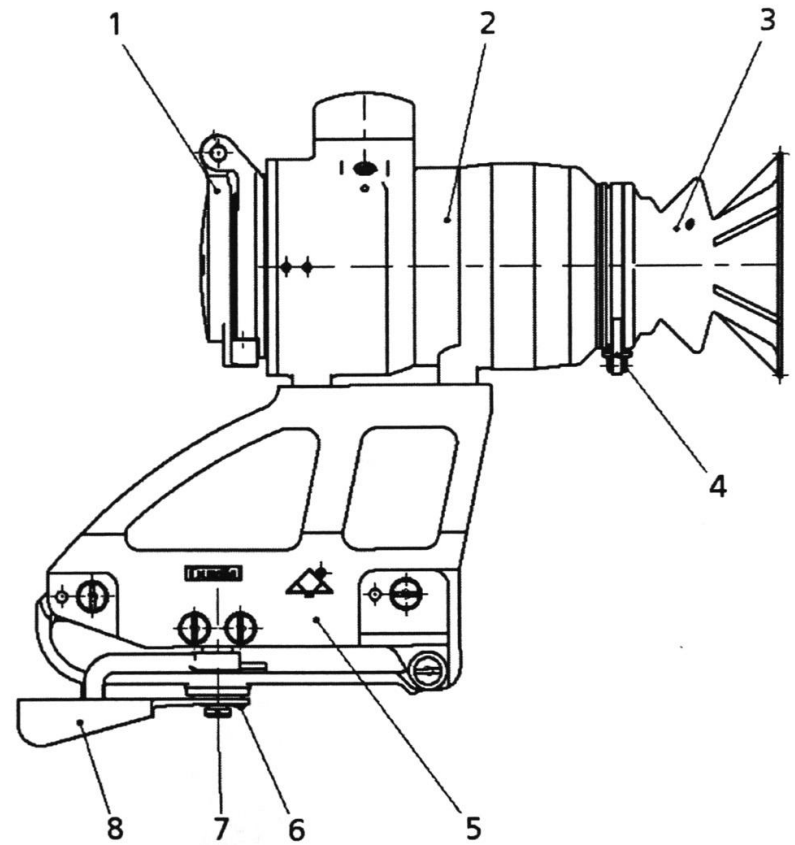

1 – cover; 2 – body; 3 – eyeshield; 4 – clamp;
5 – bracket; 6 – latch; 7 – screw; 8 – handle

Figure 1 – **PO2.8×18 S1 Sight. Side view**

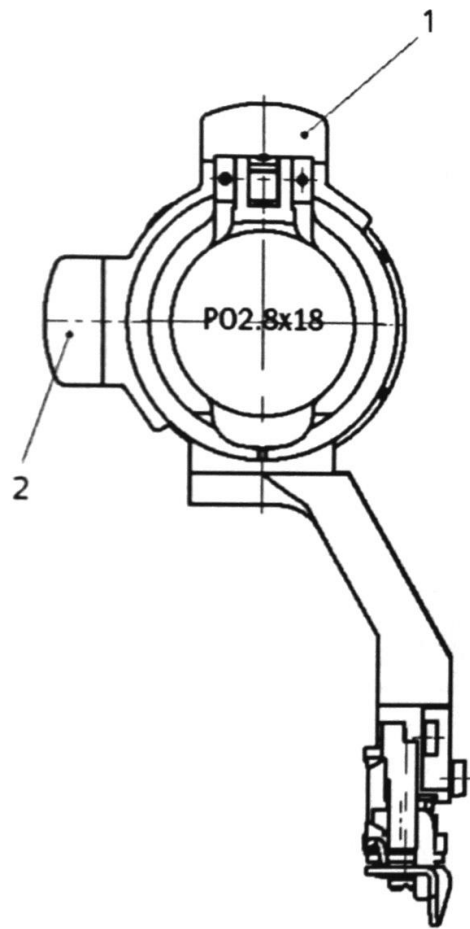

1, 2 – caps

Figure 2 – **PO2.8x18 S1 Sight. Front view**

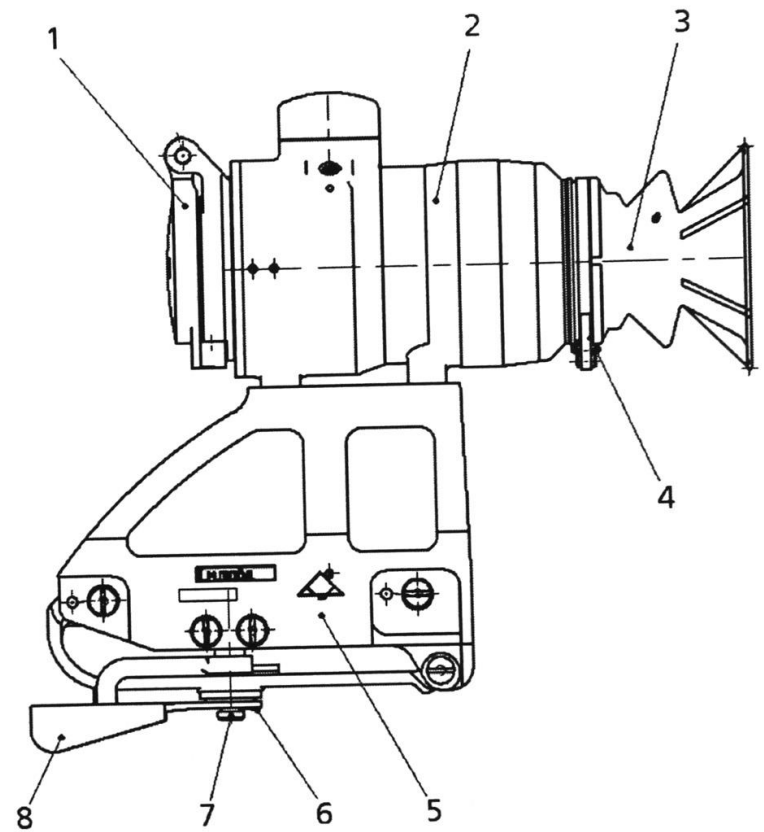

1 – cover; 2 – body; 3 – eyeshield; 4 – clamp;
5 – bracket; 6 – latch; 7 – screw; 8 – handle

Figure 3 – **PO2.8x18 S2 Sight. Side view**

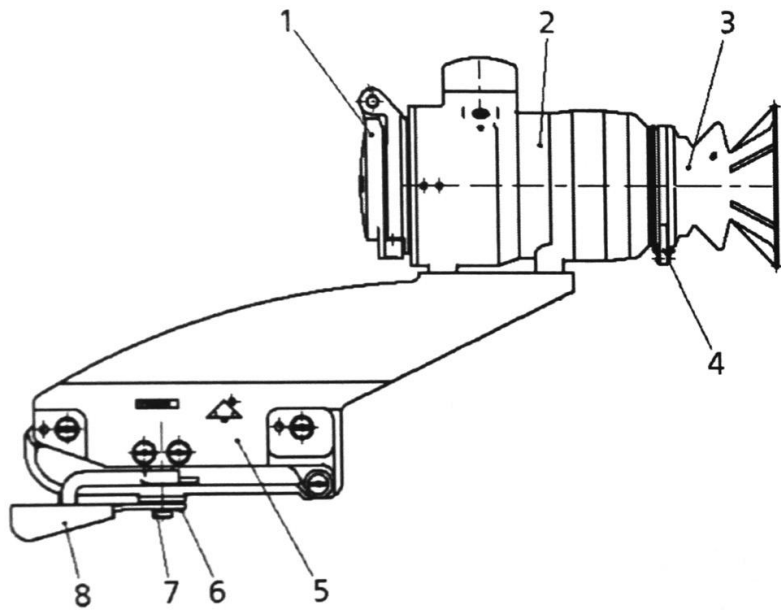

1 – cover; 2 – body; 3 – eyeshield; 4 – clamp;
 5 – bracket; 6 – latch; 7 – screw; 8 – handle

Figure 4 – **PO2.8x18 S3 Sight. Side view**

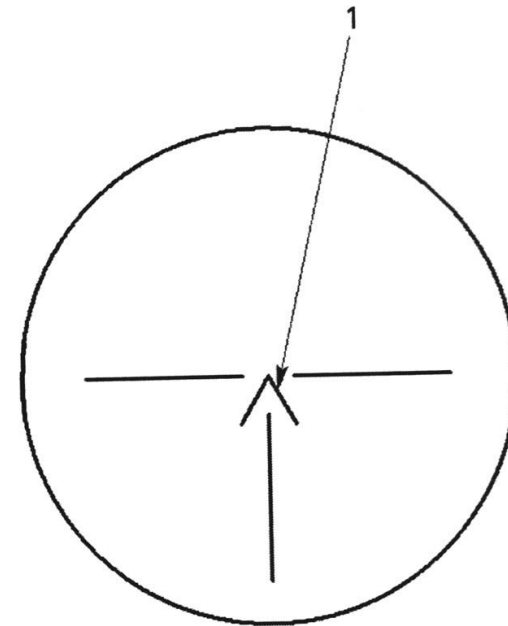

1 – Aiming mark

Figure 5 – **Field of view**

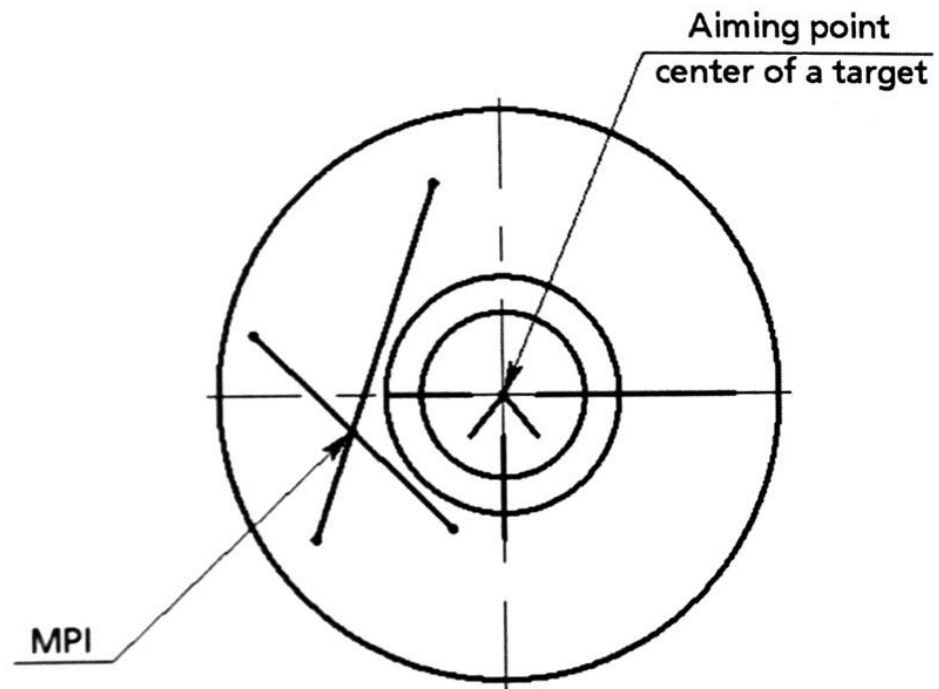

Figure 6 – **Sight adjustment on the weapon with a target**